



ST850

AUTOMATIC TURKEY DEBONING MACHINE

MODEL



DESCRIPTION



All-round automatic turkey deboner suitable for male, female, left, right, anatomically cut thigh, drum and prime wing. Please check our website and product matrix on the main folder for more information. When ordering, please provide STEEN with the electrical specifications. Also inform us with the min./max. length and weight of each part including the required capacity in pieces per minute. Please also inform if your product is water or air chilled and the time span between killing and deboning. Optimal results occur between 2 and 4°C. In case of special requirements regarding the product, don't hesitate to ask our advice.



Deshuesadora de pavo automática, completa, adecuada para el corte anatómico de muslos, contramuslos y alas de macho, hembra, izquierda, derecha. Consulte nuestra web y nuestra gama de productos en la carpeta principal para obtener más información. Al realizar el pedido, proporcione a STEEN las especificaciones eléctricas. Infórmenos también de la longitud y el peso mínima(o)/máxima(o), así como del peso de cada pieza, incluida la capacidad requerida en piezas por minuto. Rogamos nos informe si su producto se refrigera con agua o aire frío, así como del intervalo de tiempo entre el sacrificio y el deshuesado. Los resultados óptimos se producen entre 2 y 4 °C. En caso de requisitos especiales relacionados con el producto, no dude en consultarnos.



Máquina desossadora completamente automática adequada para macho, fêmea, esquerda, direita, sobrecoxa anatomicamente cortada, coxa e asa. Consulte o nosso website e matriz de produtos na pasta principal para mais informação. Ao encomendar, avise a STEEN acerca das suas especificações elétricas. Informe-nos também o comprimento e o peso mín./máx. de cada parte, incluindo a capacidade em peças por minuto. Informe-nos também se o seu produto é refrigerado a água ou ar e o intervalo de tempo entre o abate e o desossamento. Os melhores resultados ocorrem entre 2 e 4°C. No caso de requisitos especiais sobre o produto, não hesite em consultar-nos.

TECHNICAL DATA

FEATURE	DATA
Operators	1
Voltage range (1)	220- 575V 50-60Hz
Power (1)	2,23kW/3 phase
Controls	24V
LxWxH (2)	800x1620x2350 mm
Weight (3)	832 kg
Working width (2)	-
Water usage (4)	0,5l/min
Water connection	1/4"
Air usage	2m ³ /min. at 8 bar
Air connection	1/2"
Speed (5)	Variable: up to 35 pcs. per minute

(1) depending on requested voltage

(2) 1mm = 0,03937 inches

(3) 1kg = 2,20462 pounds

(4) 1l = 0.264172052 US gallons

(5) 70 CFM at 116 psi



FOOTPRINT

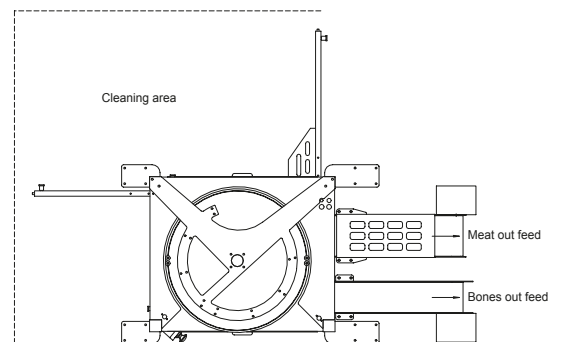
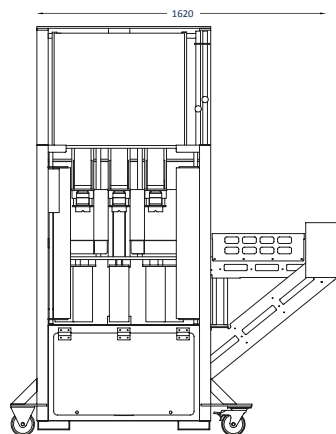
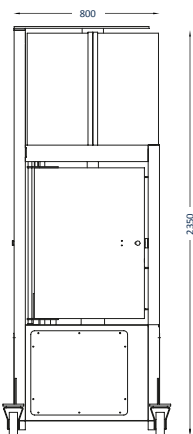

Due to the high degree of customization possibilities, technical data of the final product may vary.



OPTIONS



ST850

AUTOMATIC TURKEY DEBONING MACHINE

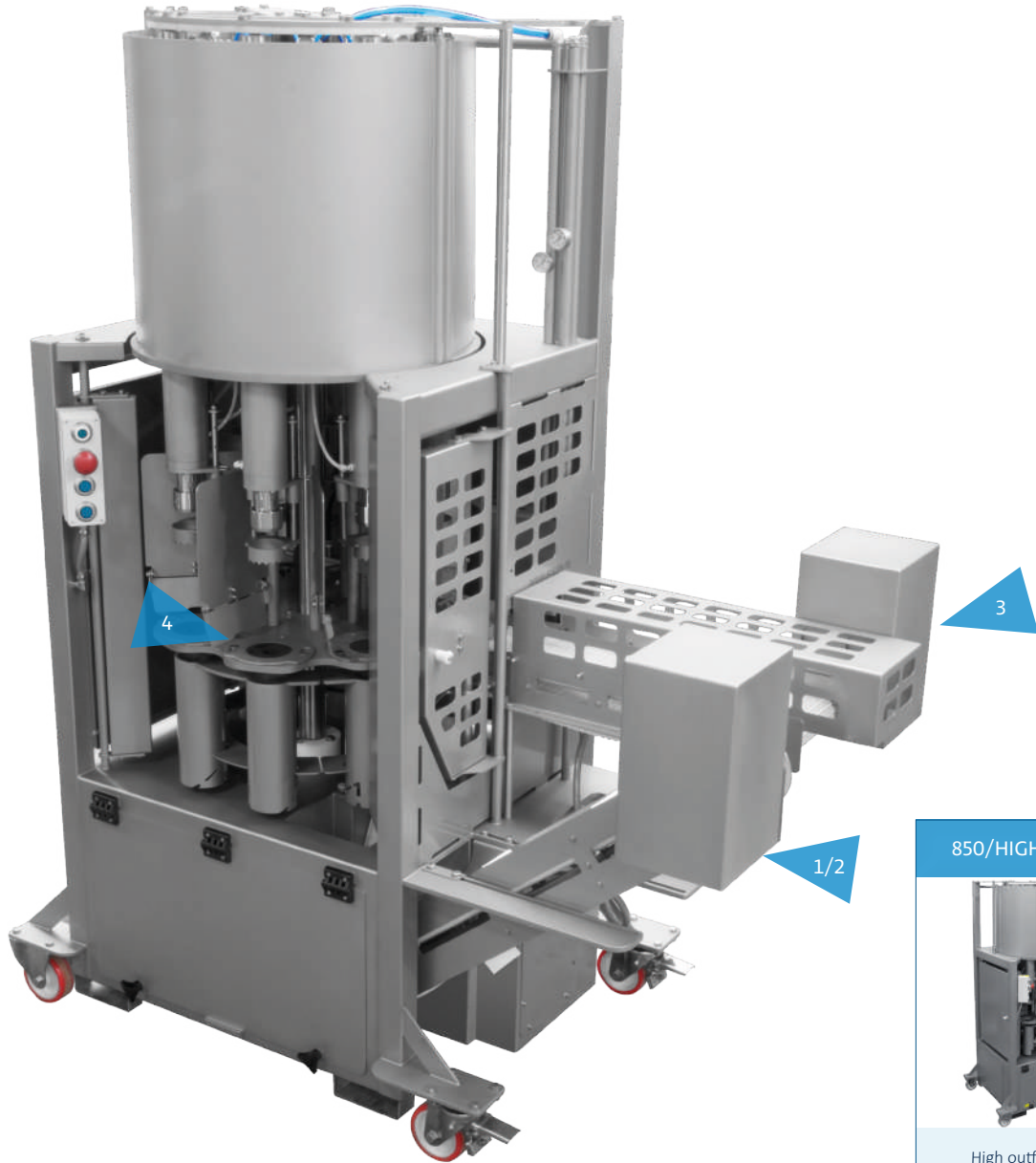

850/HIGH BONES 1



High outfeed belt- Bones

850/SHORT BONES 2



Short outfeed belt- Bones

850/LONG MEAT 3



Long outfeed belt – Meat

DIAPHRAGM 4



Diaphragms in various sizes

850/LEFT



Machine mirrored

CUSTOMIZED 5



Tailor-made solution

Due to the high degree of customization possibilities, technical data of the final product may vary.