

MESA DE CORTE  
CUTTING TABLE  
MESA DE CORTE  
TABLE DE DÉCOUPE

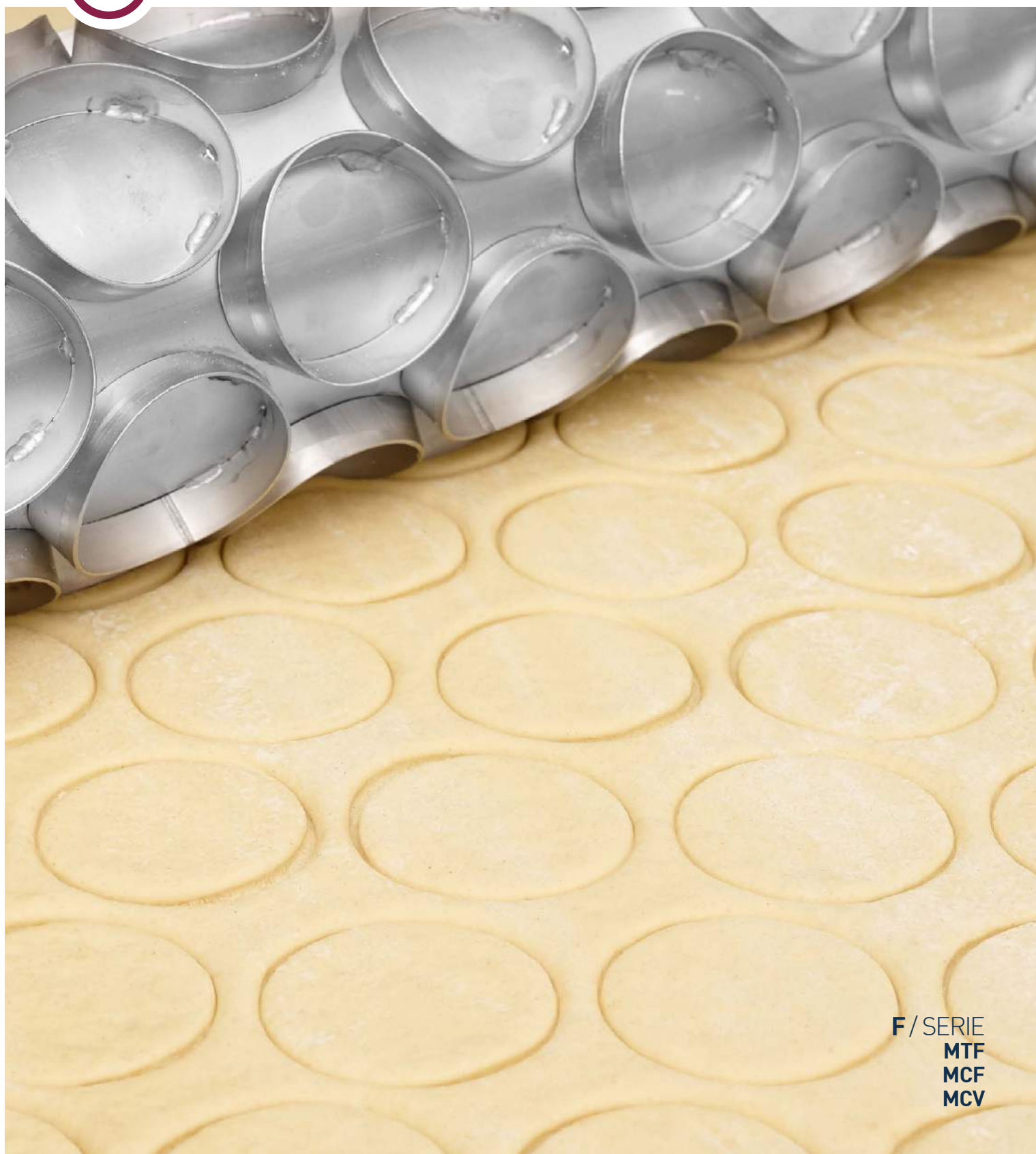

F / SERIE  
MTF  
MCF  
MCV

[inox]

Estrutura em aço inoxidável AISI304  
Stainless steel AISI304 frame  
Estructura en acero inoxidable AISI304  
Bâti en acier inoxydable AISI304



### MAM

Mesa de aparas /  
Dough collector /  
Mesa de recortes /  
Table de découpes de pâte /

### MEM

Mesa de entrada de massa / Dough  
feeding table / Mesa de entrada de  
masa / Table d'entrée pour la pâte

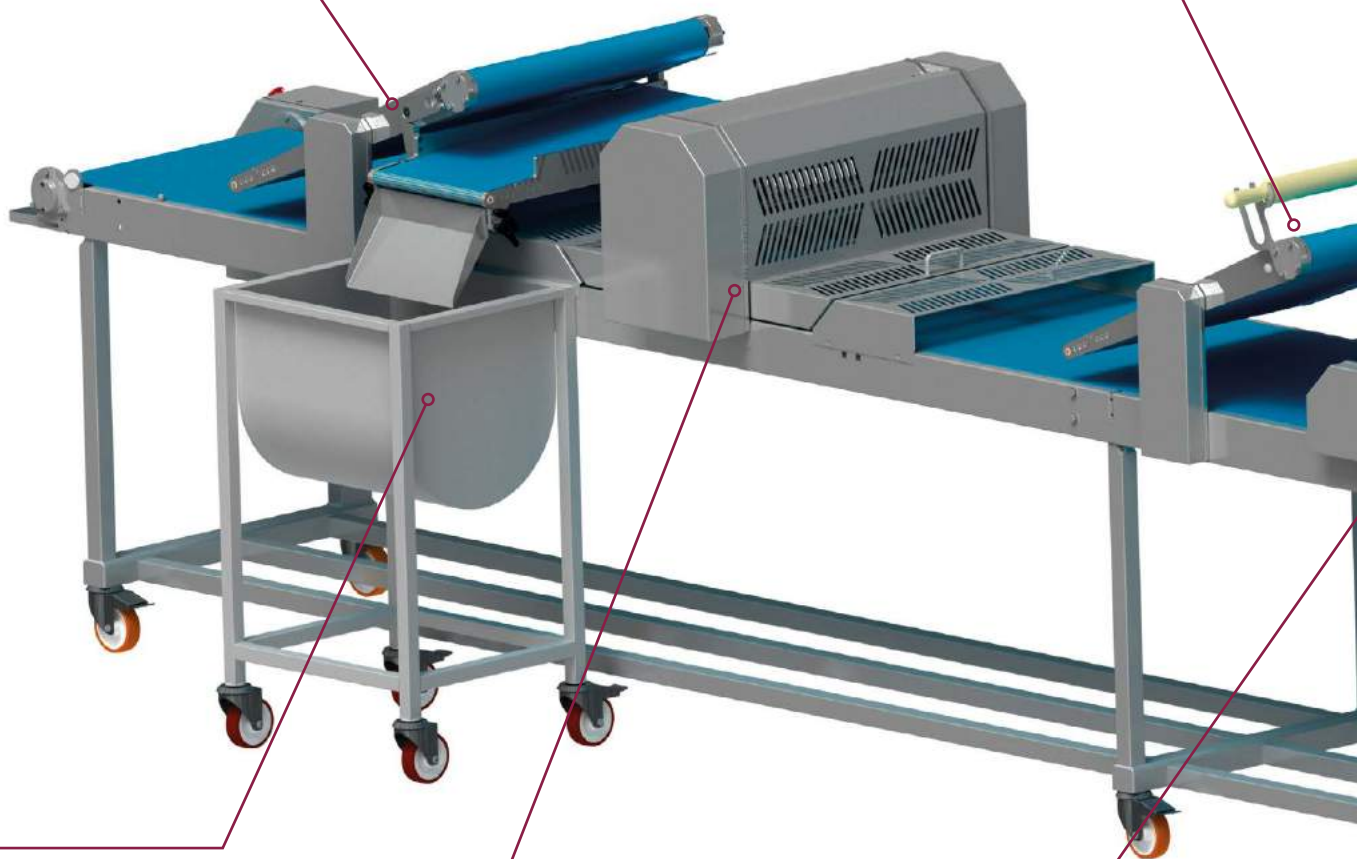

### CA1.MAM

Contentor de aparas /  
Scrap dough container /  
Contenedor de masa de residuos /  
Collecteur de miette

### ECV

Estação de corte vertical /  
Vertical cutting station /  
Estación de corte vertical /  
Station de coupe vertical

### EDM

Estação de dobragem de massas /  
Dough folding station /  
Estación de pliegue de masas /  
Station de pliage



## F / SERIE

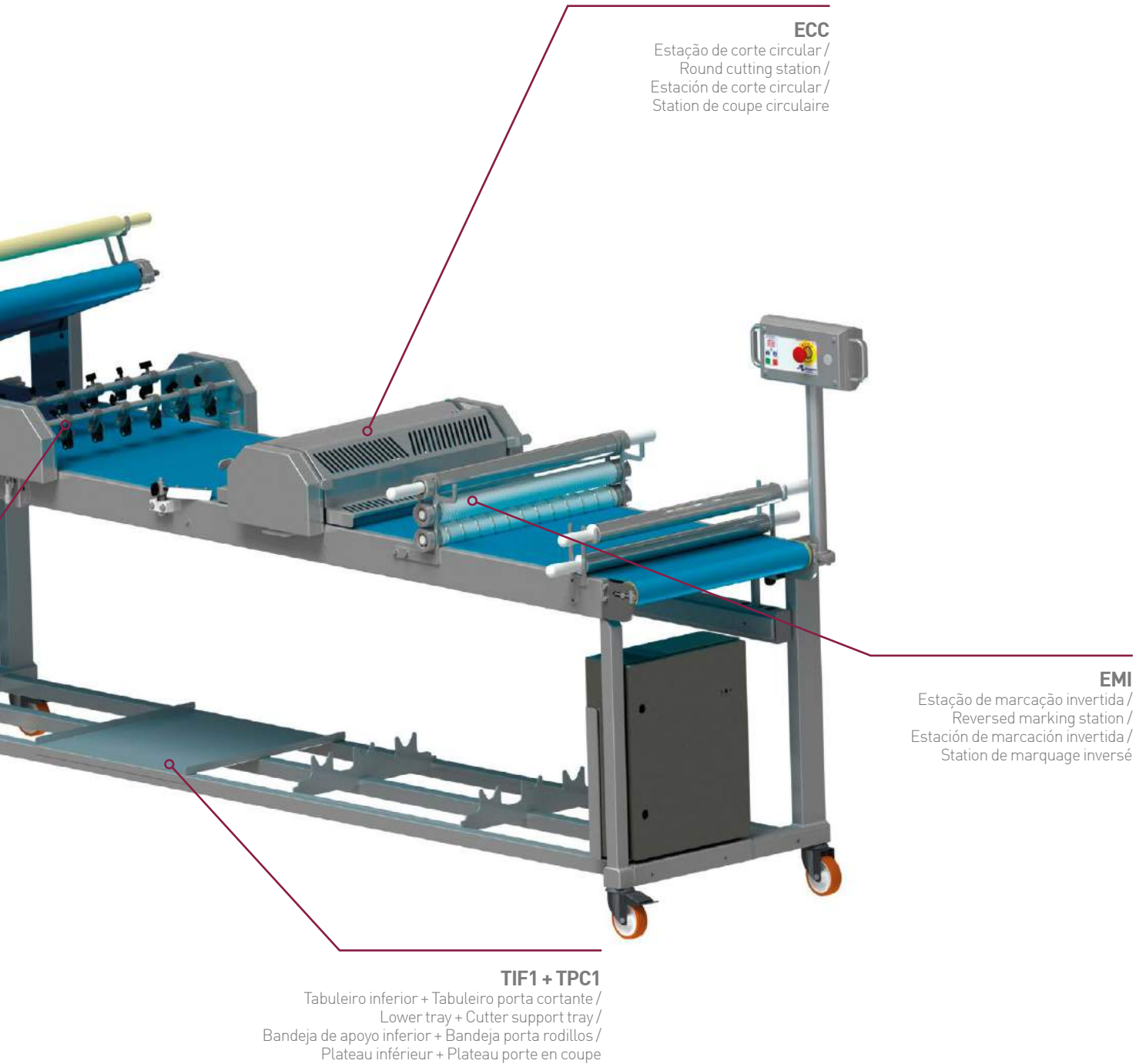

### ECC

Estação de corte circular /  
Round cutting station /  
Estación de corte circular /  
Station de coupe circulaire

### EMI

Estação de marcação invertida /  
Reversed marking station /  
Estación de marcación invertida /  
Station de marquage inversé

### TIF1 + TPC1

Tabuleiro inferior + Tabuleiro porta cortante /  
Lower tray + Cutter support tray /  
Bandeja de apoyo inferior + Bandeja porta rodillos /  
Plateau inférieur + Plateau porte en coupe



Largura da mesa / Table width / Anchoe la mesa / Largeur de la table



Comprimento da mesa / Table length / Largo de la mesa / Longueur de la table

# F / SERIE





MESA DE TRANSPORTE / CONVEYING TABLE  
MESA DE TRANSPORTE / TABLE DE TRANSPORT

## MTF



0,6

0,8

1



2|3|4|5|6|7|8

2|3|4|5|6|7|8

2|3|4|5|6|7|8



MESA DE CORTE / CUTTING TABLE  
MESA DE CORTE / TABLE DE DÉCOUPE

## MCF



0,6



2|3|4|5|6|7|8



MESA DE CORTE VERTICAL / VERTICAL CUTTING TABLE  
MESA DE CORTE VERTICAL / TABLE DE DÉCOUPE VERTICAL

## MCV



0,6



3|4|5|6|7|8

**ECC**

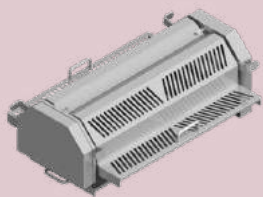

ECC600

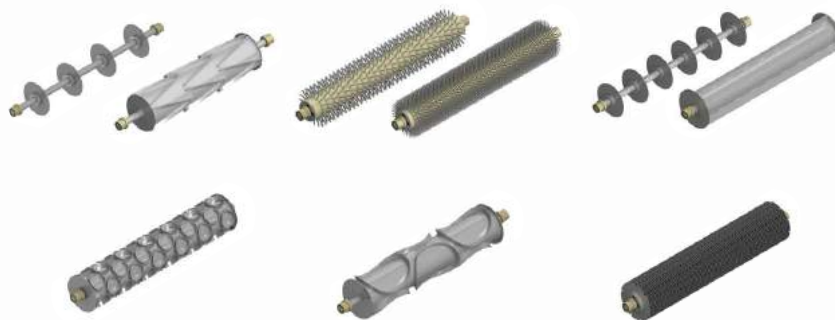

**ECV**

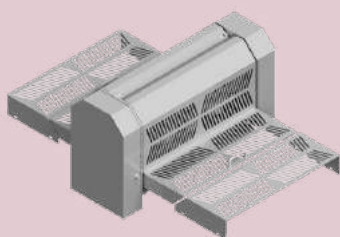

ECV600

**SIMPLES / SIMPLE / SENCILLO / SIMPLE**



**EXPULSÃO / EJECTION / EXPULSIÓN / ÉJECTION**



**EMI**

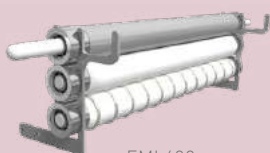

EMI.600



RMI1.EMI

**EDM**

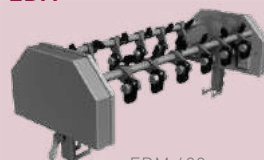

EDM.600



GDD1xx.EDM

GDE1xx.EDM

CM1.EDM

**MEM / MAM**

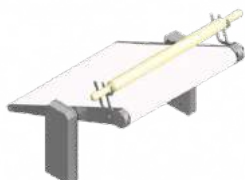

MEM600.MCF

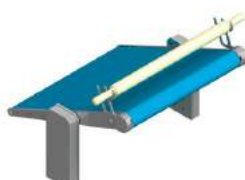

MEM600.MCV



MAM600.MCF

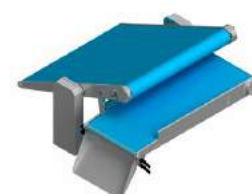

MAM600.MCV

**ACESSÓRIOS / ACCESORIES / ACCESORIOS / ACCESSOIRES**



CA1.MAM



ENF.601.MCV



TIF1



PTM1



CUV1



ANL



TPC1



PTS1



EAR600



ECT

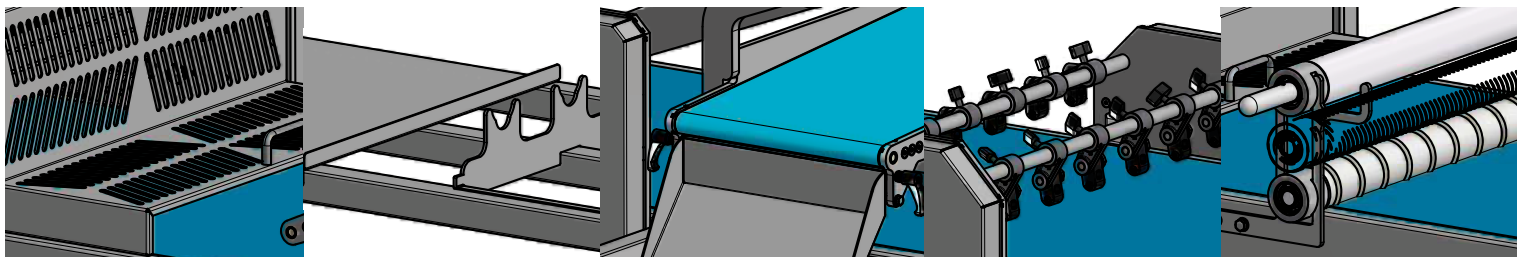

**MTF** **MCF** **MCV**

<b>ECC600</b>	<b>ESTAÇÃO DE CORTE CIRCULAR</b> Round cutting station / Estación de corte circular / Station de coupe circulaire	-	✓	✓
Acessórios / Accessories / Accesorios / Accessoires	<b>CORTANTES</b> (triangular, retangular, quadrangular, redondo, disco e outros) Cutting rollers: triangular, rectangle, quadrangular, round, disk and others / Rodillos cortadores: triangular, rectangular, cuadrangular, redondo, disco y otros / Découpoirs: triangulaire, rectangulaire, quadrangulaire, rond, disque et autres			
<b>ECV600</b>	<b>ESTAÇÃO DE CORTE VERTICAL</b> Vertical cutting station / Estación de corte vertical / Station de coupe vertical	-	-	✓
Acessórios / Accessories / Accesorios / Accessoires	<b>CONJUNTO DE CORTANTES</b> Cutter assembly / Conjunto de troquel / Ensemble de découpoirs			
<b>EMI600</b>	<b>ESTAÇÃO DE MARCAÇÃO INVERTIDA</b> Reversed marking station / Estación de marcación invertida / Station de marquage inversé	-	○	○
Acessórios / Accessories / Accesorios / Accessoires	<b>RMI1.EMI ROLO DE MARCAÇÃO INVERTIDA</b> Reversed marking rolling pin / Rodillo de marcación invertida / Rouleaux de marquage inversé			
<b>EDM600</b>	<b>ESTAÇÃO DE DOBRAGEM DE MASSAS (SEM GARFOS)</b> Dough folding station (without forks) / Estación de pliegue de masas (sin plegadores) / Station de pliage (sans les fourches)	-	○	○
Acessórios / Accessories / Accesorios / Accessoires	<b>GDE1xx.EDM GARFO DOBRAGEM À ESQUERDA</b> / Left-hand dough folder/ Plegador de masa a la izquierda / Fourche de pliage à gauche <b>GDD1xx.EDM GARFO DOBRAGEM À DIREITA</b> / Right-hand dough folder / Plegador de masa a la derecha / Fourche de pliage à droite <b>CCM1.EDM CALCADOR DE MASSA</b> / Dough press / Rodillo aplastador de masa / Presseur de pâte	-	○	○
<b>MEM</b>	<b>MESA DE ENTRADA DE MASSA</b> Dough feeding table / Mesa de entrada de masa / Table d'entrée pour la pâte	-	○	○
<b>MAM</b>	<b>MESA DE APARAS</b> Dough collector / Mesa de recortes / Table de découpes de pâte	-	○	○
Acessórios / Accessories / Accesorios / Accessoires	<b>ENF.601 ENFARINHADOR</b> / Automatic flour duster / Harinador / Farineur automatique <b>EAR600 ESTAÇÃO ALONGADORA REGULÁVEL</b> / Adjustable dough stretching station / Estación extendidora de masa regulable / Station d'étirement réglable <b>ECT-ANL. COMANDO TÁTIL OU ANALÓGICO</b> / Touchscreen or analog control panel / Pantalla táctil o mandos analógicos / Écran tactile ou Commande electromécanique <b>CUV1 CUVETE DE INGREDIENTES</b> / Ingredients draw support / Soporte de harinador / Support de covete <b>TPC1 TABULEIRO PORTA CORTANTE</b> / Support tray for cutters / Bandeja porta rodillos / Plateau porte en coupe <b>TIF1 TABULEIRO INFERIOR</b> / Lower tray / Bandeja de apoyo inferior / Plateau inférieur <b>PTM1 PRATELEIRA MÓVEL DE APOIO</b> / Moveable support shelf / Tabulero móvil de apoyo / Plateau de support mobile <b>PTS1 PRATELEIRA DE SAÍDA</b> / Output shelf / Tabulero de salida / Plateau de sortie <b>RLM6 ROLO DE MASSA</b> / Dough rolling pin / Rodillo de masa / Rouleaux <b>CRT1 CONTENTOR DE RESÍDUOS C/ ESTRUTURA DE APOIO</b> / Waste container with support structure / Contenedor de masa de residuos con estructura de apoyo / Collecteur de résidus avec structure d'appui			



UNIÃO EUROPEIA  
Fundos Europeus Estruturais  
e de Investimento