

Production hourly:  
3800 Kg / h

  
weight  
cookie  
50 gr

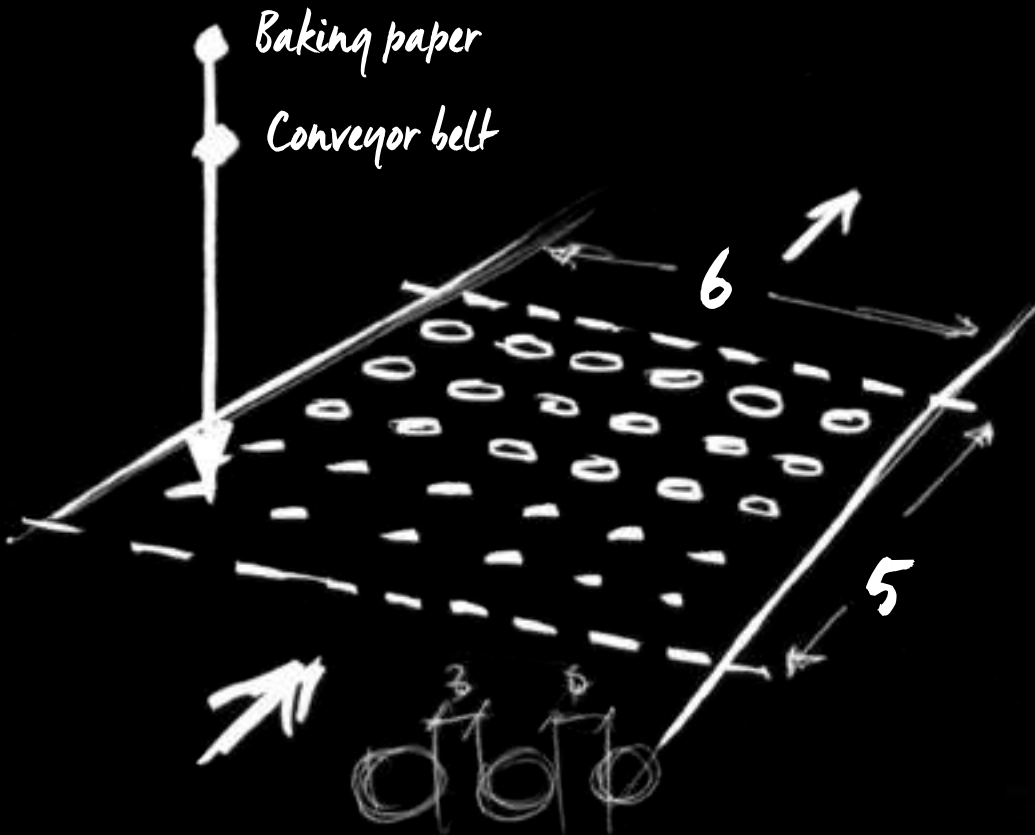
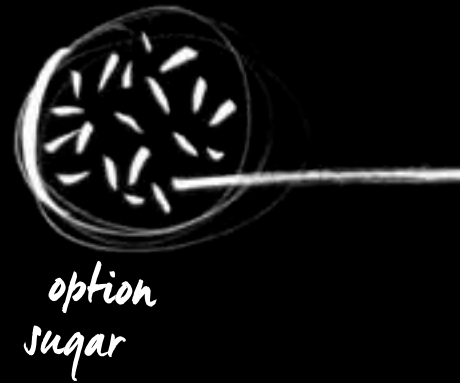

Filling inside:  
chocolate  
jam

$\frac{12}{3}$



dough  
with chocolate  
inclusion

*[Handwritten scribble]*



Crispy

British



Thumbprint



# COOKIES PRODUCTION LINE

## MISSION

Supplied an automatic line for the production of raw cookies dosed on paper foils

Produce three products types: wire-cut, filled and jam decorated cookies

Handle an high production capacity

Provide an automatic control system by means of data and recipes storing

Reach an high dosing and filling precision

To clean the injection head at side of the production line

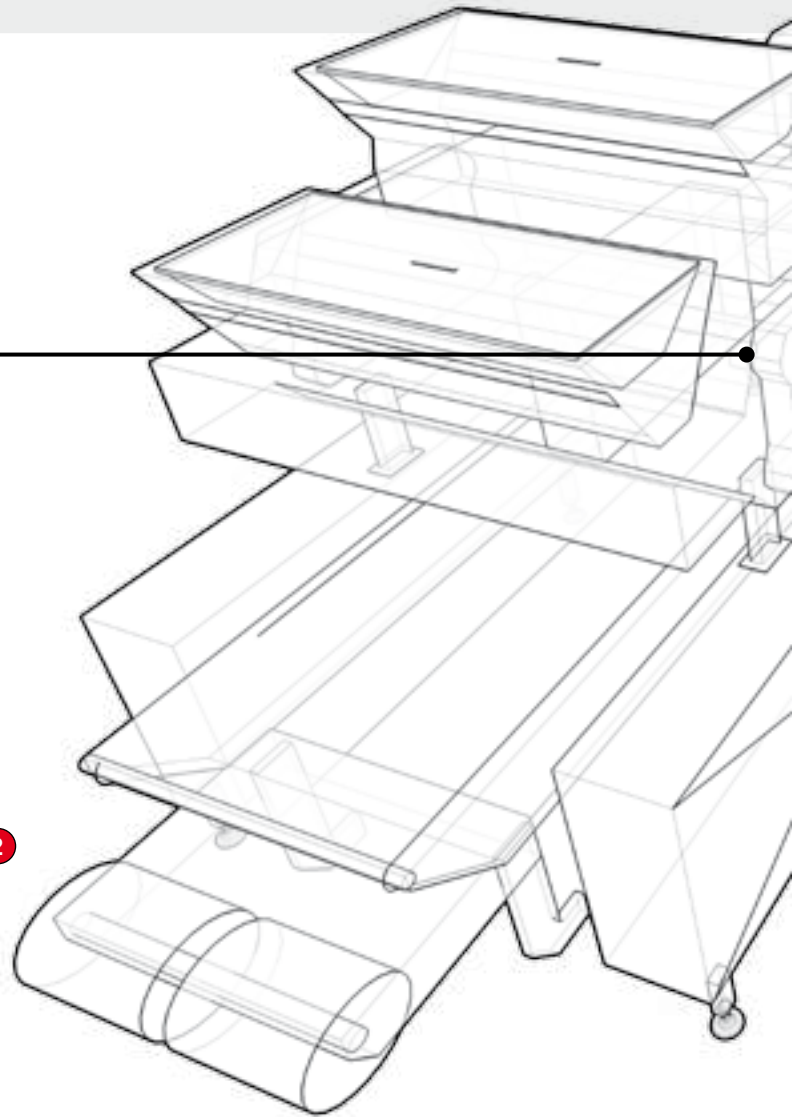

## TECHNICAL SOLUTION

**Alimec supplied a line composed by a gear pumps dosing unit with wire cut system and ancillary filling head. This allow the production of standard cookies or filled ones**

Machine completely driven by servomotors, suitable for several products types and high performance

Extractable head on a side trolley for cleaning operations at side of the line

1

Blocking device equipped with heated moulds, suitable for cookies moulding

Dry ingredients dispenser (sugar, chocolate chips ...) with 'target' distribution on product

2

PLC and HMI for the control of the machine and the storing of data and recipes

3

Wire cut interchangeable device, driven by servomotor

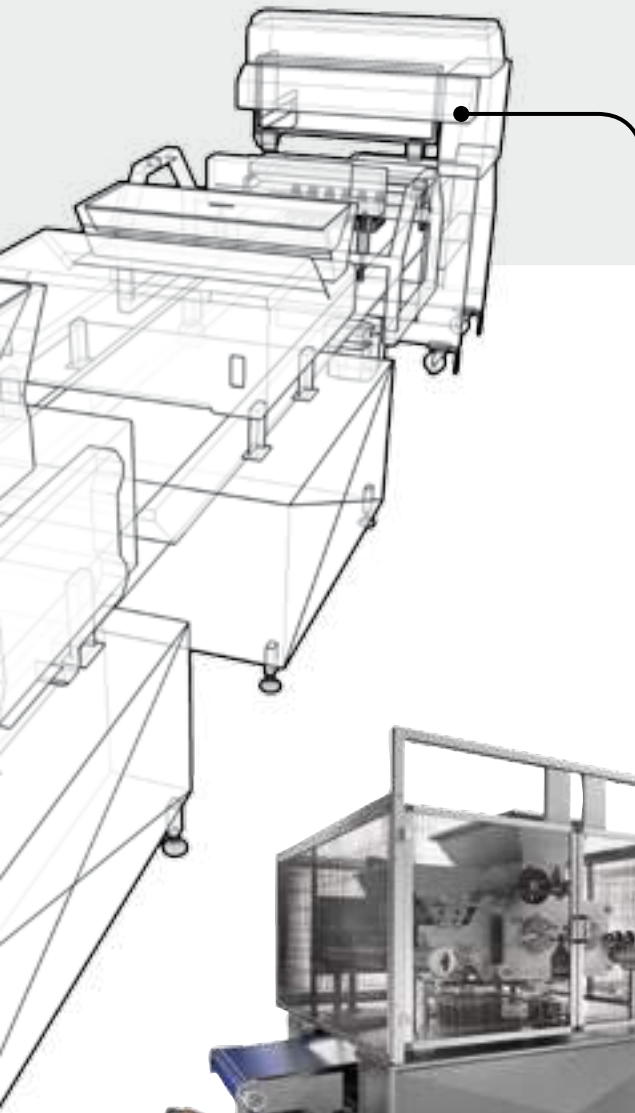

## PRODUCTS



COOKIE  
WITH CHOCO-DROPS



FILLED COOKIE  
WITH CHOCO DROPS



THUMBPRINT  
COOKIE

3



## NUMBERS

Production / hour:	<b>93.600 pcs/h</b>
Capacity:	<b>4.680 Kg/h</b>
Rows number:	<b>12 products</b>
Line working width:	<b>800 mm</b>

## DO YOU KNOW THAT...

Alimec supply solutions to dose directly on oven band or in baking tray.

Our sales department and our expert team can provide you with more information: contact us!