

pitch
70 mm

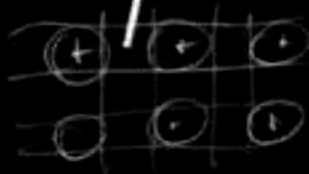

Vertical filling

Horizontal filling

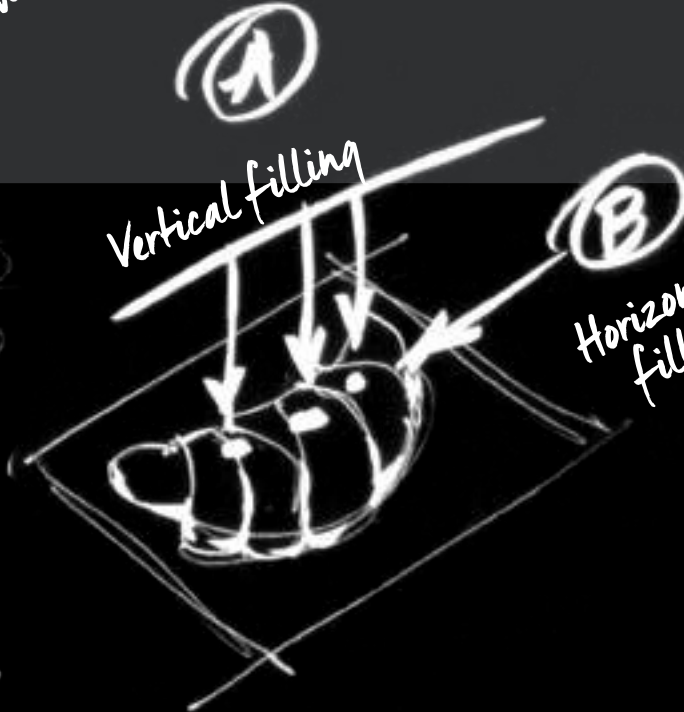

500 pcs/min

4-6

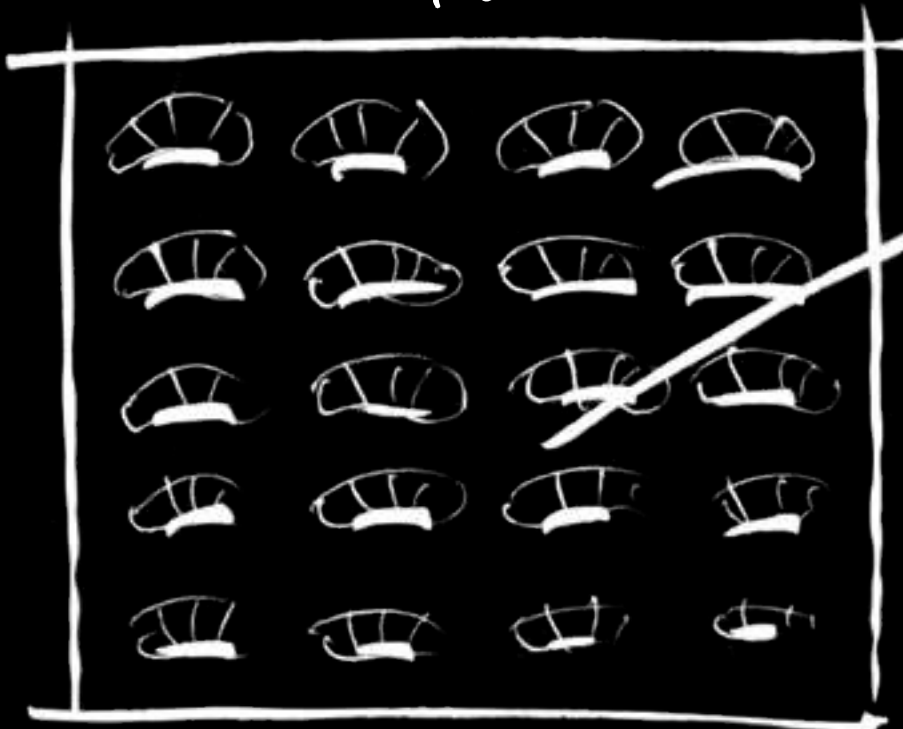

pattern
4 x 2 / 6 x 8

5-8

Jam filling

Tray

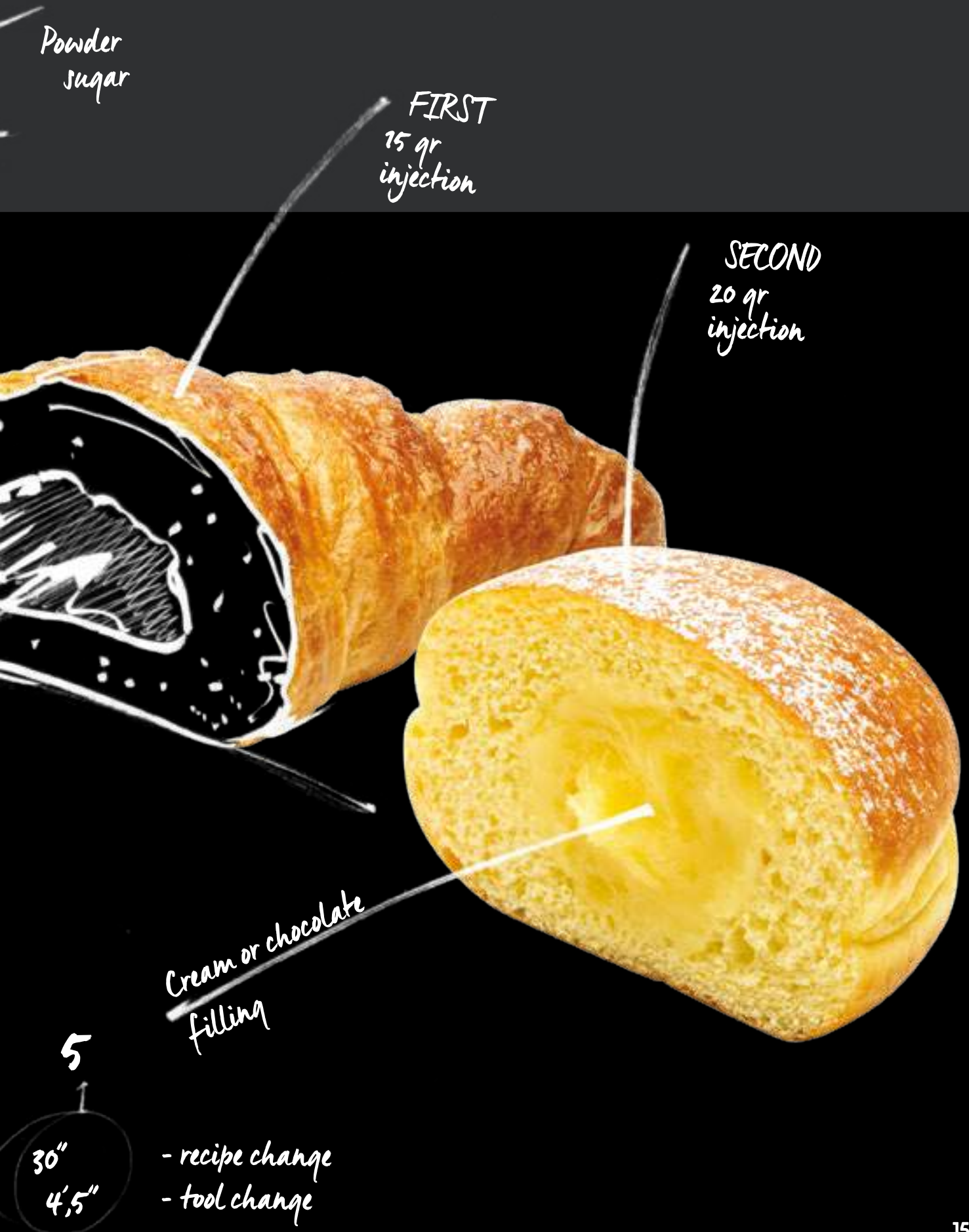



VERTICAL INJECTION LINE FOR PRODUCTS IN TRAY

MISSION

Provide a line for vertical injection of croissant in tray, with rapid change of filling flavour

Handle an high production capacity

Inject different types of croissant and pastry products with several tray configuration and fillings

Install the injection line on an existent plant

Reach an high dosing precision



1



2

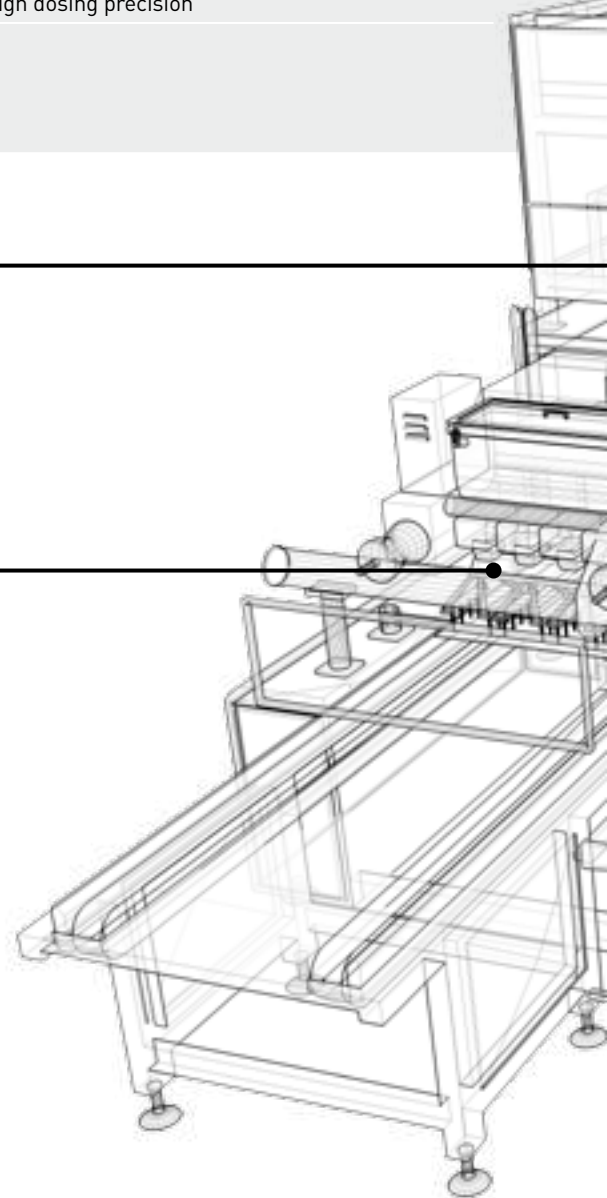

TECHNICAL SOLUTION

Alimec supplied an injection line for croissant and pastry products

Injection units completely driven by servomotors, suitable for several products types and high performance

1

No.2 injection heads, no.1 of which for fast change of filling flavour, complete with quick release system of injection plate for time optimization

2

Injector hopper with temperature control heating system

3

Depaning unit suitable to depans products from the filling line to the packaging system.

Trays handling system made with materials suitable to reduce the noise, wear and tear of trays and ensure accuracy in the transport and positioning

PLC and HMI for the control of the production line and the storing of data and recipes

PRODUCTS



VERTICALLY INJECTED
CROISSANT

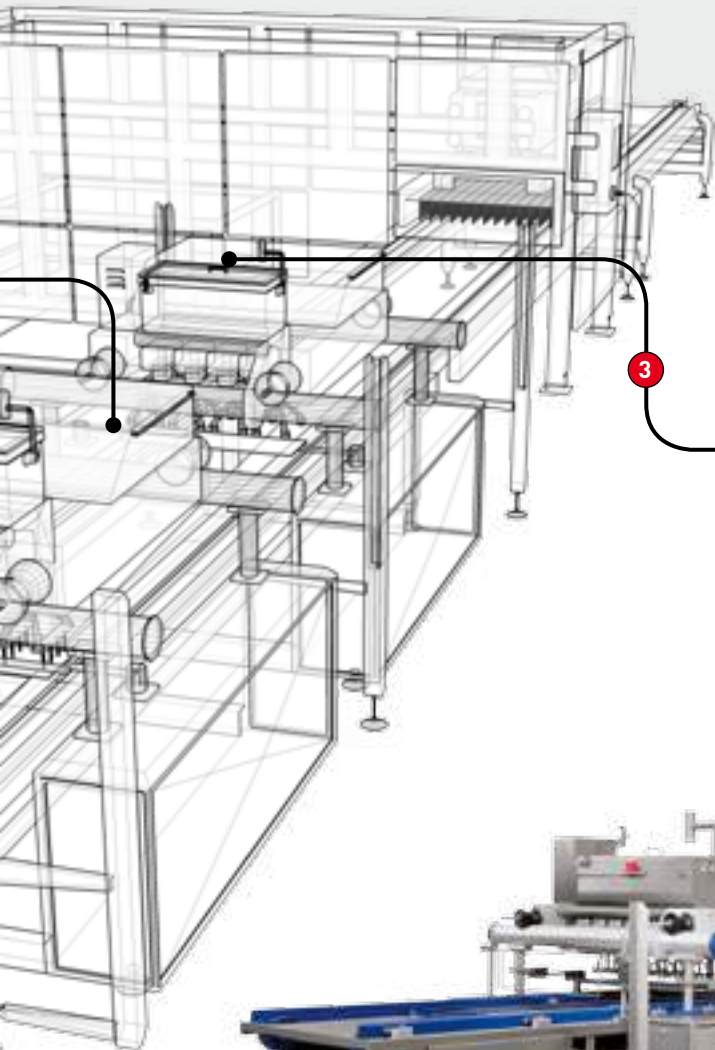

NUMBERS

Production / hour:	36.000 pcs/h
Filling qty / hour:	468 Kg/h
Trays / minute:	12,5 /min
Tray size:	800x600 mm

DO YOU KNOW THAT...

The same line gives the option of double filling injection.

Our sales department and our expert team can provide you with more information: contact us!

Alimec can supply different type of depanning units according to the products.



VERTICAL INJECTION LINE ON CONVEYOR BELT

MISSION

Supply a line for vertical injection of donuts

Handle a medium/high production capacity

Install the injection line on an existent plant

Inject the product with single or double filling, with automatic alignment system

Ensure an high dosing precision

Automatic feeding of fillings

To clean the injection head at side of the production line

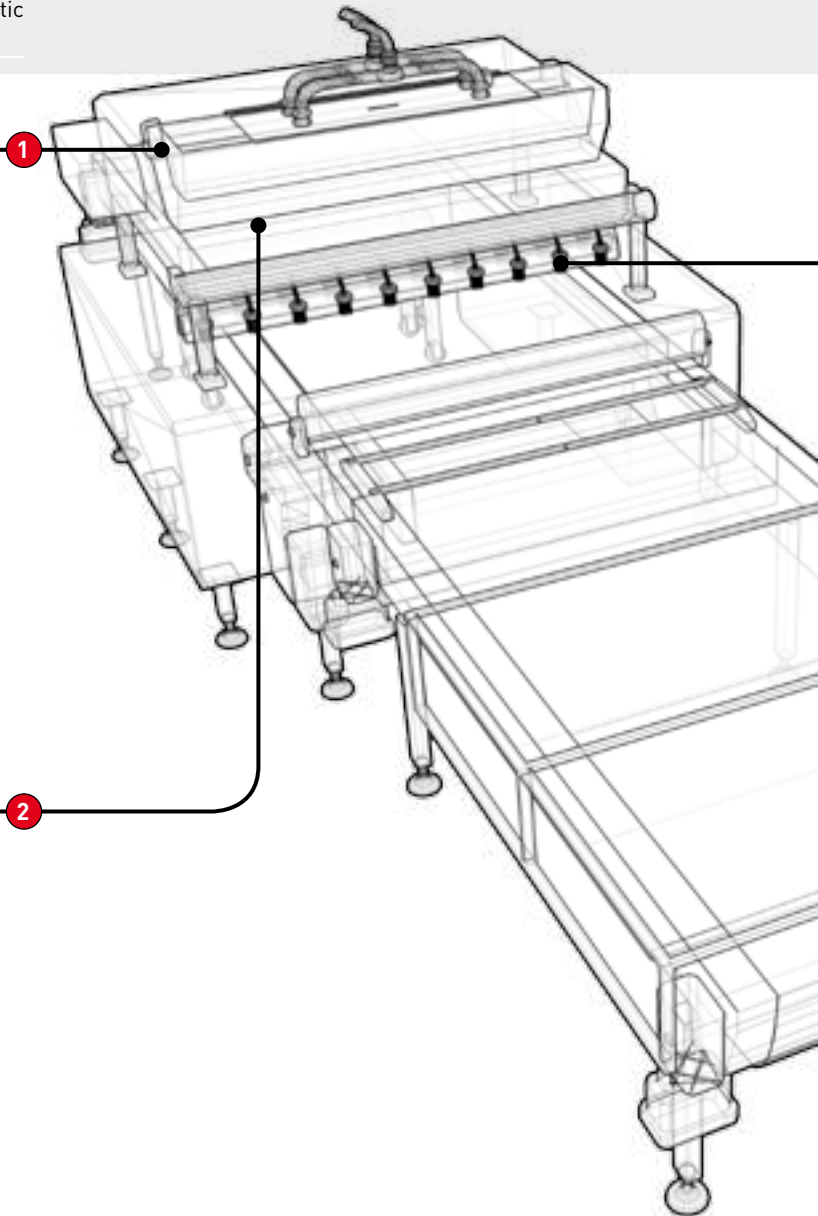

TECHNICAL SOLUTION

Alimec provided an injection line inside available space

Injection head equipped with double cylinders and hopper with divider in order to inject two different fillings 1

Using of high tech components and motors

PLC and HMI for the control of the production line and the storing of data and recipes

Feeding pumps control by level devices and manage through HMI

Injection head removable on a special trolley with remote control in the washing room 2

Injection plate with quick release system, equipped with trolley 3

PRODUCTS



INJECTED
DONUT



DOUBLE COLOUR
FLAVOUR INJECTED
DONUT

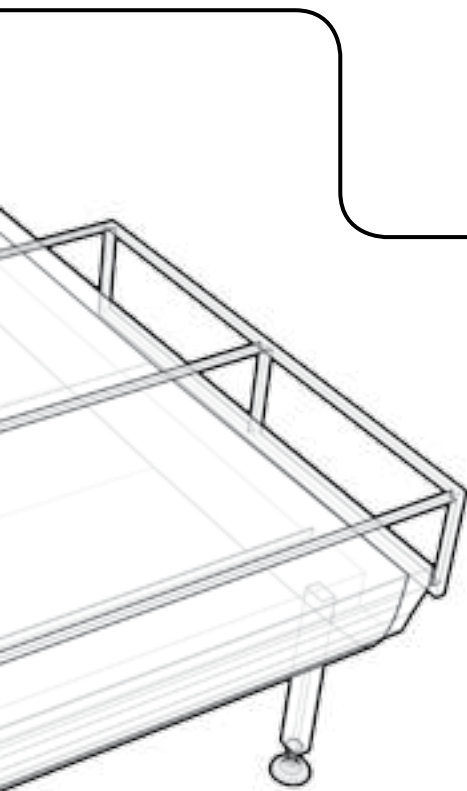

3



NUMBERS

Production / hour:	33.000 pcs/h
Filling qty / hour:	495 Kg/h
Rows / minute:	39,2 /min
Rows number:	14 products
Line working width:	1.650 mm

DO YOU KNOW THAT...

It is possible to inject horizontally products using the same injection unit.

Our sales department and our expert team can provide you with more information: contact us!

HORIZONTAL INJECTION LINE

MISSION

Provide a line for horizontal injection of croissant with 'long-filling' effect

Handle a medium/high production capacity

Ensure an high dosing precision

Inject the product with single or double flavour, with automatic alignment system

To clean the injection head at side of the production line



1



2

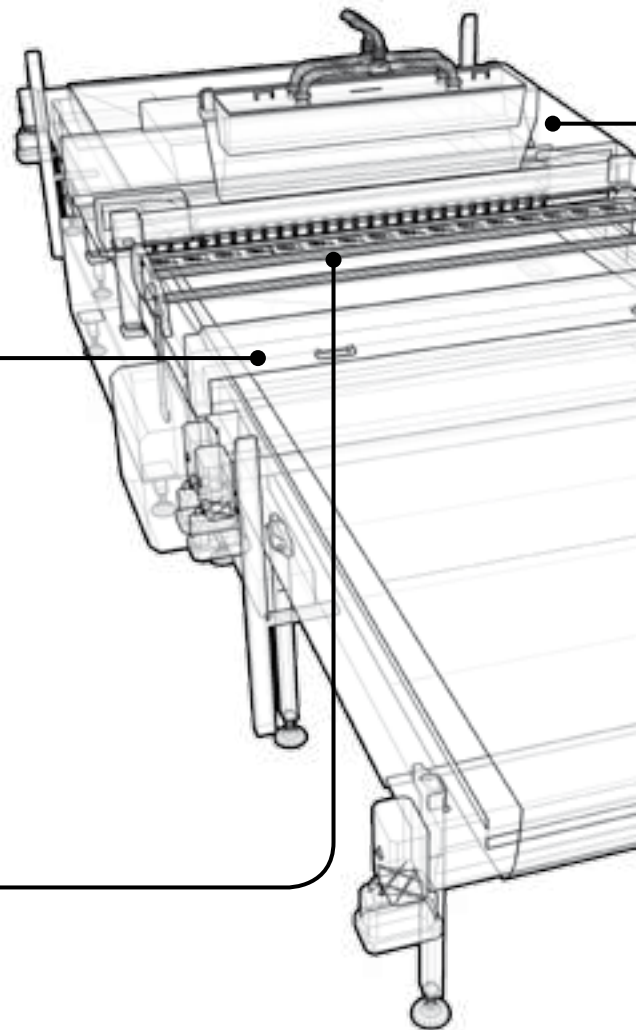

TECHNICAL SOLUTION

Alimec supplied a line with injection head driven by servomotors to ensure an accurate and continuous movement, with parameters adjustable through display (HMI)

Photocells for croissant reading and injection only in presence of product

1

Injection plate extractable on a side trolley for cleaning operations

2

Alignment system to guarantee product positioning during injection phase

3

Injection head removable on a special trolley with remote control in the washing room

PLC and HMI for the control of the production line and the storing of data and recipes

PRODUCTS



HORIZONTALLY INJECTED
BREAD/BRIOCHE



HORIZONTALLY
INJECTED CROISSANT

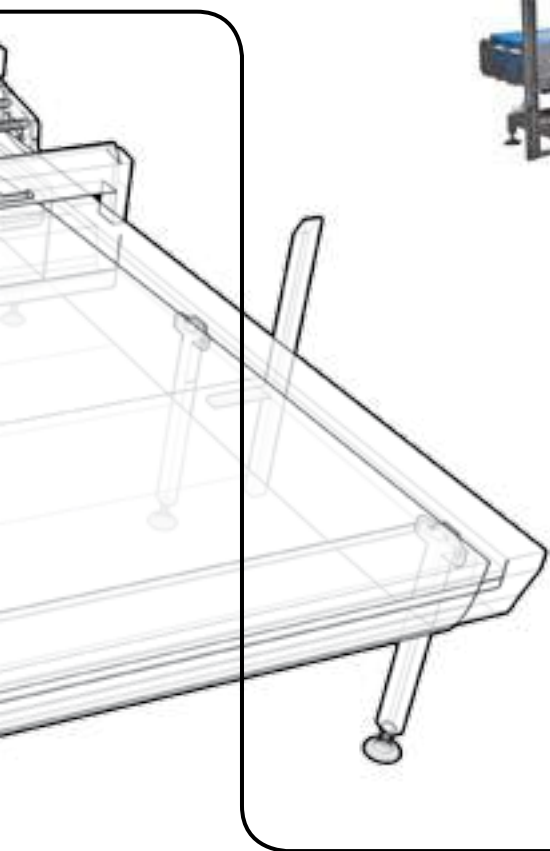

3

NUMBERS

Production / hour:	26.500 pcs/h
Filling qty / hour:	397 Kg/h
Rows / minute:	18,4 /min
Rows number:	24 products
Line working width:	2.000 mm

DO YOU KNOW THAT...

It is possible to inject vertically products using the same injection unit.

Our sales department and our expert team can provide you with more information: contact us!